

**It's so easy**

**FALCON-Family**

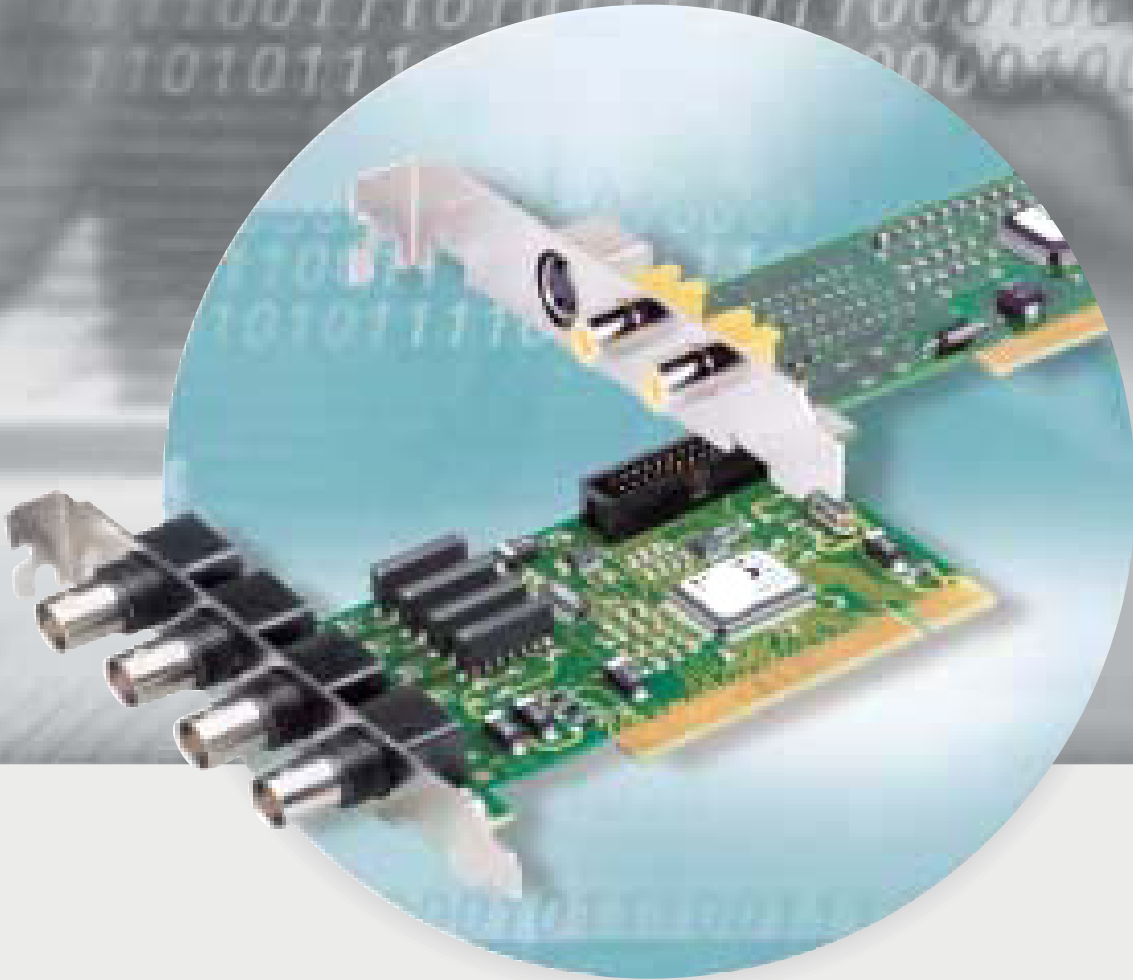

# **FALCON-Family**





**FALCON, FALCON-LP, FALCONplus, FALCONduo, FALCONquattro**

More than 30.000 worldwide sales.  
The Frame Grabbers for Standard Video Signals.

The Falcon series of frame grabbers are one of the most popular selling boards world-wide for professional applications. The unique software interface grants you a lot more possible fields of application than other boards would allow. And thanks to many example applications in the source code you can integrate the boards very easily into your present software. FALCON-frame grabber boards are functioning with all applications that work with standard video signals: from industrial automation over medical technology up to safety engineering

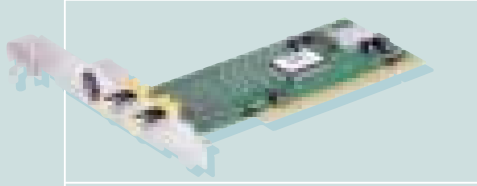
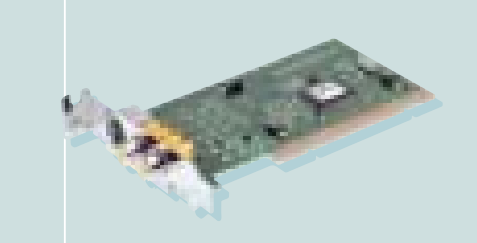
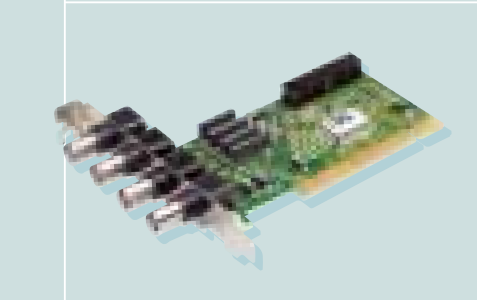
– from dactylogram systems and face recognition to building management systems, ultrasonic, microscoping and X-raying of all kinds.

FALCON frame grabber is available for evaluation for 14 days, free of charge and without obligation. We have a commitment to service excellence and customer support that continues after your purchase. We believe that you should be able to protect your investment with quality after sales support.

	<p><b>FALCON</b> as standard: 1 SVHS-input, 2 CVBS*-inputs, EEPROM, PAL, NTSC, SECAM, TWAIN-driver available as option</p>	<p><b>Einsatzgebiete</b> medical technology industrial automation safety engineering</p>
	<p><b>FALCON-LP</b> 1 SVHS-input, 2 CVBS*-EEPROM, PAL, NTSC, SECAM, TWAIN-driver available as option  integration into mini-PCs with Low Profile PCI-slot</p>	<p>medical technology, industrial automation safety engineering</p>
	<p><b>FALCONplus</b> 4 CVBS*-inputs, EEPROM, PAL, NTSC, SECAM, an input-device specially developed to grant top speed switching rates of the input channels, 12 digital inputs, 8 digital outputs, TWAIN-driver available as option, optocoupler for dig. I/O as option</p>	<p>safety engineering industrial automation medical technology</p>
	<p><b>FALCONduo</b> 8 (4+4) CVBS*- EEPROM, PAL, NTSC, SECAM, parallel framegrabbing from 2 cameras, slot extension to the port of the inputs 5-8, 12 digital inputs, 8 digital outputs, optocoupler for dig. I/O as option</p>	<p>safety engineering industrial automation medical technology</p>
	<p><b>FALCONquattro</b> 16 (4+4+4+4) CVBS*- EEPROM, PAL, NTSC, SECAM, parallel framegrabbing from 4 cameras, slot extension to the port of the inputs 5-16, 12 digital inputs, 8 digital outputs, optocoupler for dig. I/O as option</p>	<p>safety engineering industrial automation medical technology</p>
	<p><b>HAWK</b> 1 SVHS-input, EEPROM, PAL, NTSC, SECAM, trigger-input, DSUB-socket</p>	<p>industrial automation, medical technology</p>



### Direct precise video digitalisation

The FALCON-family supports all colour- and monochrome cameras with SVHS- or composite video output. Up to 768 x 576 pixels are digitized very precisely and directly transferred into the PC-RAM. The image size is hardware-set by a scaler.

### Much tempo between the inputs

High switching rates between the inputs are vitally important especially in safety engineering and industry. FALCONplus sets high standards here: the maximum possible performance for a cost that's really unusual.

### If you still want more: parallel frame grabbing from several cameras

FALCONduo and FALCONquattro can in addition capture in parallel from video signals that are definable per channel. Up to 120 frames per second is possible. Settings like image size, brightness, contrast, ... are definable for each channel.

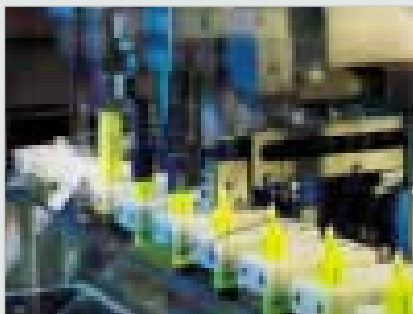

# FALCO

### Multi-board support is also possible

Due to its interrupt-sharing capability, the driver supports simultaneous operation of several cards in one PC. With each additional board the number of framegrabbers are increased in the PC – with FALCONquattro the increase is by four. That means with four FALCONquattro's you can have 16 frames digitized simultaneously. Please contact us concerning the bandwidth of your PC. It affects image size and colour depth.

### Common settings

You can set all parameters like image size, region of interest, contrast, brightness, colour value and colour saturation conveniently in the digitized video data.

### Video images in real-time

The video signals are displayed as live images on the VGA-monitor of the PC – they are transferred via the PCI-bus in video real-time without no CPU-loading.

### Overlays in the live image

What is extraordinary about the FALCON-series: you can blend flicker-free overlay-information into the live video image: graphics, date and time, overlays with CAD-data and much more. This feature is already contained in the development kit. With support from DirectDraw (DD) and the modes DD-back-

buffer and DD-overlay-surface (not compatible with all VGA-cards), you can use the desired mode depending on the VGA-card in use. These settings involve virtually no CPU-loading.

### Keep your VGA-card – thanks to DirectDraw

DirectDraw, defined by Microsoft, is the interface between VGA card and framegrabber for video display under Windows. It is supported by the FALCON-family in all modes of displaying. So you can still apply your present VGA-card and completely utilise all attributes like colour formats, onboard memory, scaling up of the video image, alpha blending, image reflection etc. Here there is in most cases virtually no CPU-loading.

### Digital inputs and outputs, maximum safety

12 digital inputs and 8 digital outputs offer much scope for external sensors like photo sensors, proximity switches, motion detectors or a control unit. You can set directly 24 V voltage level by an optocoupler card available as an option. The inputs (12 mA/channel) are protected against short-circuits and false polarities; an outside fuse protection against overcurrent exists (100 mA/Channel).

Type of board	Number of boards	Number of camera inputs	Parallel inputs	Frame rate per board
FALCONquattro	1	16	4	bis 120 fps
FALCONquattro	2	32	8	bis 240 fps
FALCONquattro	3	48	12	bis 360 fps
FALCONquattro	4	64	16	bis 480 fps
FALCONduo	1	8	2	bis 60 fps
FALCONduo	2	16	4	bis 120 fps
FALCONduo	3	24	6	bis 180 fps
FALCONduo	4	32	8	bis 240 fps
FALCONplus	1	4	1	bis 30 fps
FALCONplus	2	8	2	bis 60 fps
FALCONplus	3	12	3	bis 90 fps
FALCONplus	4	16	4	bis 120 fps

# FALCON

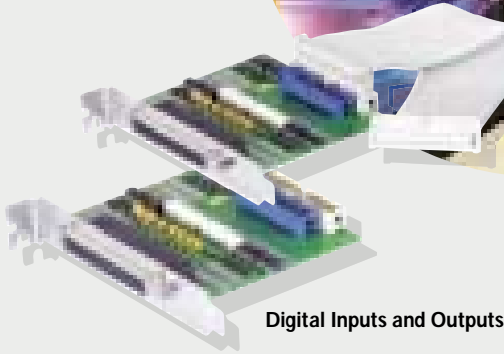

Digital Inputs and Outputs

## WDM- driver, TWAIN-driver and Active-X available

You can perform the integration into standard programs with the free WDM-driver, VfW-driver or an Active-X. A TWAIN-driver is available as an option.



When you want to blend a flicker-free overlay (e.g. graphics or text) into the live image, then just use the interfaces provided. Besides, our driver permits direct 3D-viewing, image processing from 3D-cameras and storage of video sequences. To allow you to see the performance of our SDK, we provide many demo programs as application. The source code of these applications are written in C/C++ programming for the boards and helps you with the integration of the board into your own programs.

## Unique: the Software Development Kit (SDK)

The extensive and high-performance SDK is the greatest strength of the FALCON-family. With it, we enable you to utilise all attributes of your hardware. Memory management like single memory management or ring buffer- and double buffer management are also well integrated as the DirectDraw interface for flexible displaying of the video images.



Video playback mode	DirectDraw	Transfer	CPU-loading for live video displaying	Overlay from dialogue windows over live image	Real graphics – and text-overlay over live image
Bitmap	no	DMA in PC	yes	yes	yes
Primary Surface	yes	DMA in VGA	None	yes	no
Backpuffer	yes	DMA in VGA	Almost none	yes	yes
Overlay Surface	yes	DMA in VGA	Almost none	yes	no

- Up to 16 video inputs
- Up to 12 digital inputs / 8 digital outputs
- Multi-board support for all boards (up to 16 channel frame grabber = 4 x FALCONquattro)
- Real Time Hardware Scaling x- and y- Direction, Interpolated
- Text- and graphics-overlay in live image by DirectDraw
- EEPROM to which data may be written (can be used as dongle)
- Software Development Kit for Windows XP, 2000, ME, NT 4.0 98, 95
- Very easy programming and examples in source code
- WDM-, Active-X, Vfw drivers available free of charge
- MPEG4-, MPEG2-, MPEG1- and MJPEG-harddisk-recording with free AVI-DLL

### The SDK all you need:

- **Initialization and termination**  
Setup and termination of the interface to the hardware
- **Image acquisition and memory management**  
Allocation of the image memories, switching of the image memories, ...
- **Double- and multiple-buffering**  
Setup of the list of image memories, ring buffer, interlock of memories, ...
- **Selection of the operation modes and re-reading of the settings**  
Setting, cancelling of all parameters
- **Reading and writing of the EEPROMs**
- **Saving and loading of images**
- **Video display**
- **Additional DirectDraw-funtions**  
Overlay on/off, overlay display, DD back-buffer mode, DD primary surface mode, DD overlay surface modus
- **Event handling (interrupt-controlled framegrabbing)**

### The FALCAVI-library is now included free of charge

The substantial extension library FALCAVI permits the recording of video sequences and whole movies on harddisc in different formats (e.g. MPEG4, MPEG2, MPEG1 or MJPEG). Since driver version 4.0 it is included as free of charge within the delivery – together with the program SoftComp for demonstration of the library.



SOFTCOMP

### Functional range of the FALCAVI-library

- Initialization and termination
- Handling of AVI files  
Writing of video streams into file  
Replay functions for playback of video streams
- Compression and decompression by the installed codecs
- Writing and reading of video sequences on resp. from the harddisc
- Deinterlacing functions (eliminates the interlace effect of the two half-images in case of motion)

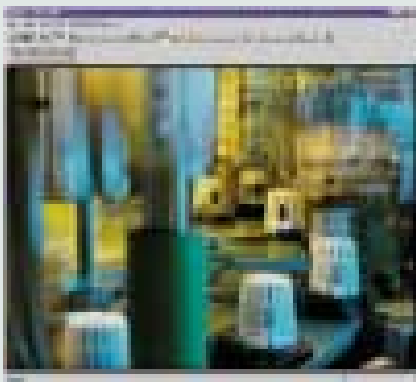

Source code is included in scope of delivery

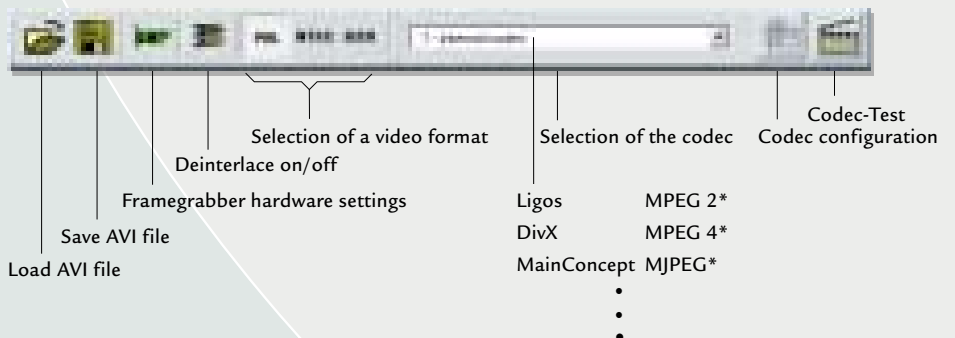

\*) no part of delivery

### BLOCK DIAGRAM FALCONduo/FALCONquattro

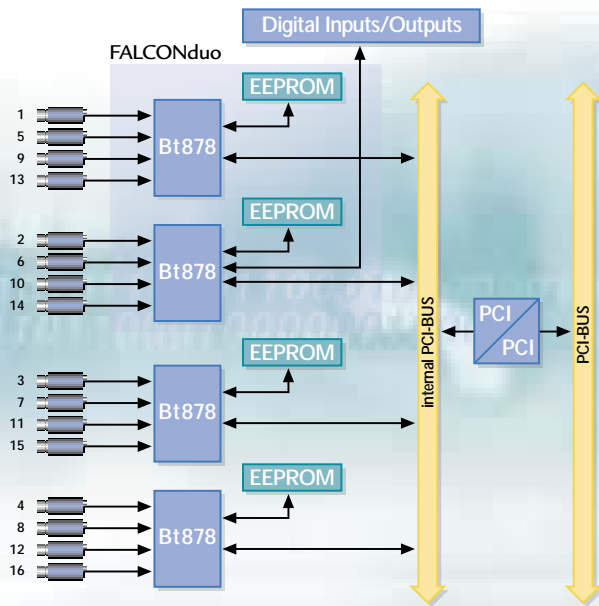

### BLOCK DIAGRAM FALCONplus

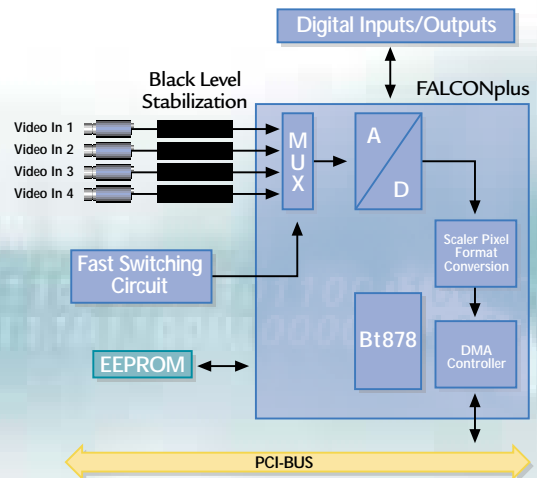

### DELIVERY:

- PCI-board
- Driver for Windows 95, 98, NT4.0, ME, 2000, XP
- Extension library FALCAVI with MPEG4-, MPEG2-, MPEG1- und MJPEG-support
- documentation

### ORDER DETAILS:

■ IS-FALCON	PCI-board
■ IS-FALCON-LP	PCI-board
■ IS-FALCONPLUS	PCI-board
■ IS-HAWK	PCI-board
■ IS-FALCONduo	PCI-board
■ IS-FALCONquattro	PCI-board
■ IS-SLOT-4	Extension board with 4 BNC-sockets incl. connecting cable
■ IS-SLOT-D26	Extension board with 2 x DSUB26-sockets, 16 x Video In
■ IS-CABL-D26-8-FDQ	Break-out-video-connecting-cable DSUB26 on 8 x BNC
■ IS-PIRANHA-OPTO	Optocoupler card for FALCONplus, FALCONduo, FALCONquattro incl. connecting cable to the framegrabber
■ IS-TWAIN	TWAIN-driver for FALCON-family and EAGLE

Please note: the FALCON-boards are sold as OEM-products to corporate clients only.